



**FAST AND
EFFICIENT
SWEEPING**

| | |
|------------------------------|------|
| INTRODUCTION | P.3 |
| V13 MODEL | P.4 |
| V9 MODEL | P.5 |
| ADAPTATIONS V9-V13 | P.7 |
| OPTIONS | P.9 |
| FINISHING BRUSH | P.11 |
| V7 MODEL | P.12 |
| WHY CHOOSE ACTISWEEP | P.14 |
| APPLICATIONS PICTURES | P.15 |
| CONTACT US | P.20 |



V-CONCEPT, A REVOLUTIONARY INVENTION

ACTISWEEP V-CONCEPT is a patented technology design for large amounts of waste or materials. It has V-shaped rows of brushes collecting rubbish into the centre of the sweeper, thus allowing a faster and more efficient sweeping.

More than 10 years of development and experience are obvious in many details. Quality, functionality and accuracy are key elements for Actisweep. V-Concept® advanced sweeping technology aims at a specific role: preventing the scattering.

Our control quality unit combined with our manufacturing process for special brushes allows us to deliver a high-performance range with a longer life-span!

ASSENTS :

- ⌒ Fast sweeping of all sorts of materials, on any type of floor
- ⌒ Very low dust emission
- ⌒ Allows to sweep up large amounts in a single time

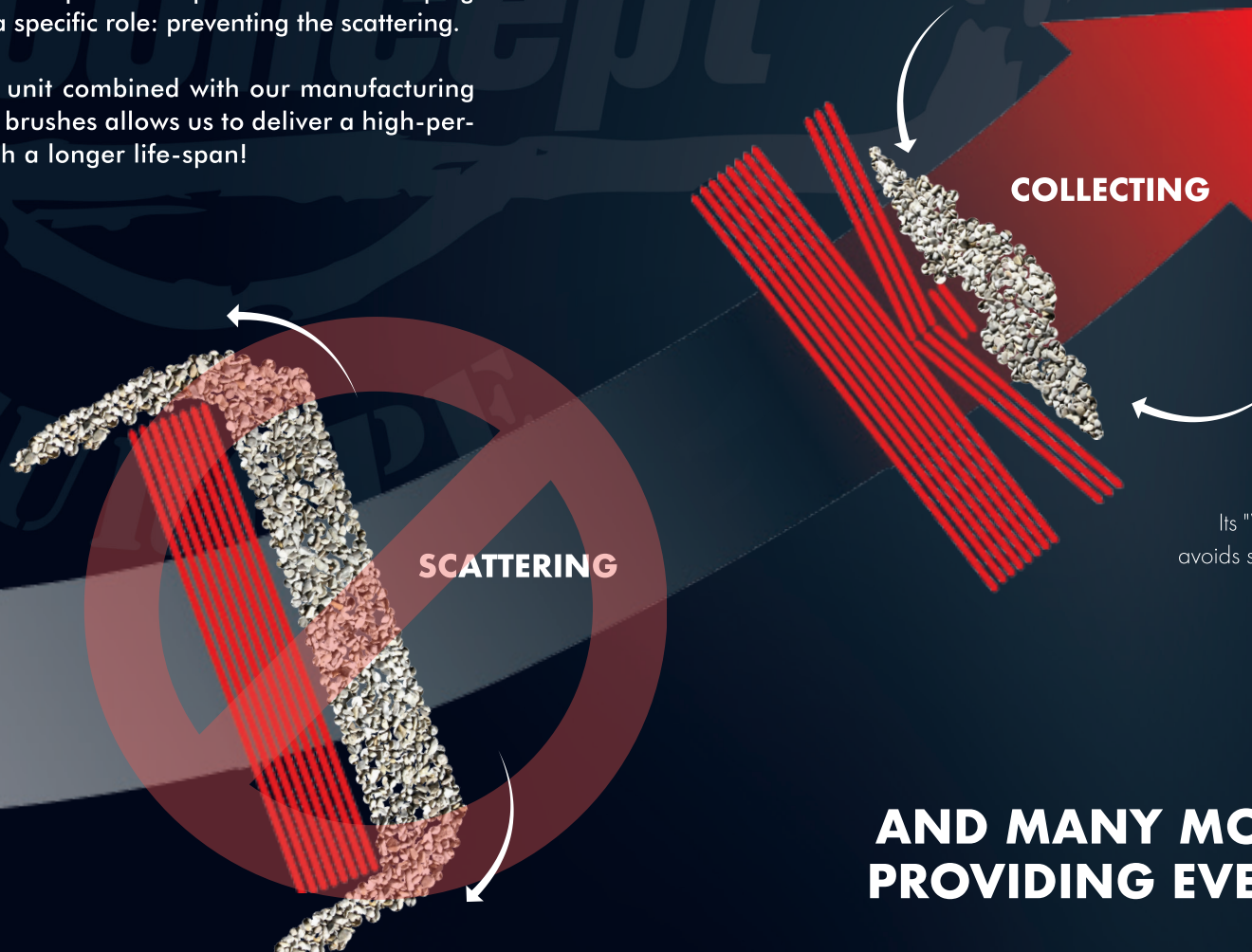

**"COLLECTING
INSTEAD OF
SCATTERING"**

Actisweep® unique V-Concept®, allows to collect rubbish into the centre of the sweeper. Its "V-shape" system prevents rubbish dispersal and avoids side windrows!

**AND MANY MORE ARGUMENTS
PROVIDING EVERY GUARANTEE!**

V13 MODEL

TECHNICAL DESCRIPTION

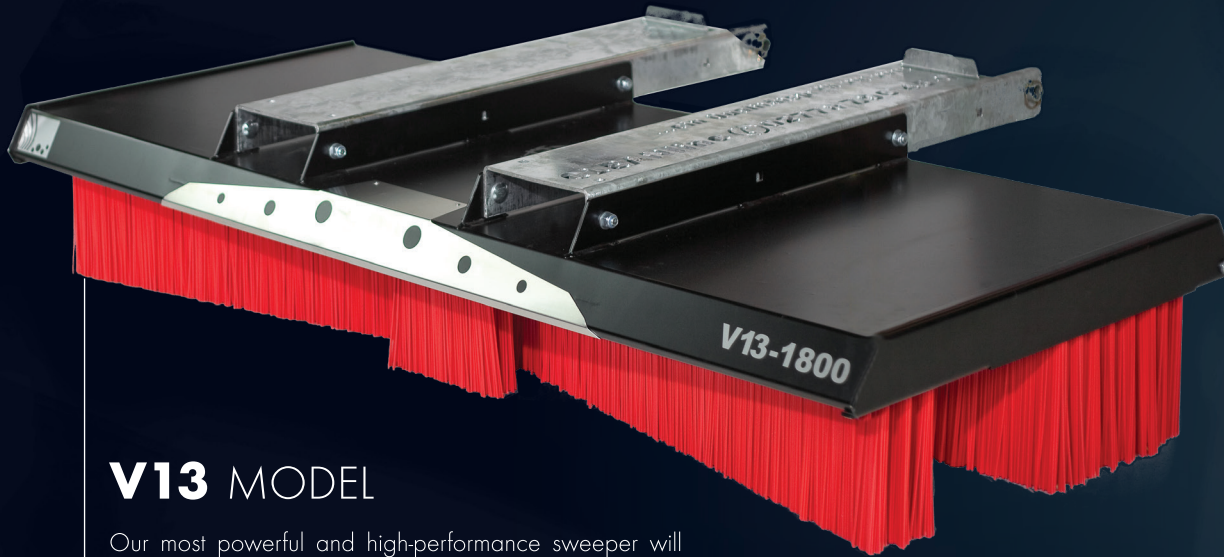

V13 MODEL

Our most powerful and high-performance sweeper will prove to be infallible for all your daily sweeping operations.

Designed for the most demanding applications, the V13 sweeper has -as indicated by its name- 13 rows of brushes: 8 straight rows, 3 rows with a V-shape at the front to collect rubbish into the centre and 2 mini-rows at the very front of the "V".

6 widths available, ranging from 1500mm à 4800mm



Most frequent applications:



AGRICULTURE



PUBLIC WORK
PUBLIC ROAD



RECYCLING

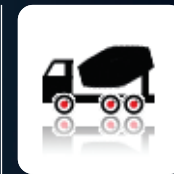

READY-
MIXED
CONCRETE



MATERIALS



V9 MODEL

Our mid-range sweeper, still very powerful, efficient and reliable. First class product for numerous sweeping operations.

Designed for demanding applications, the V9 sweeper has- as indicated by its name- 9 rows of brushes: 4 straight rows, 3 rows with a V-shape at the front to collect rubbish into the centre and 2 mini-rows at the very front of the "V".

6 widths available, ranging from 1500mm à 4800mm

Most frequent applications:



LANDSCAPES



EQUESTRIAN CENTRES



SNOW REMOVAL



MUD/SLUDGE REMOVAL

SPECIFICATIONS

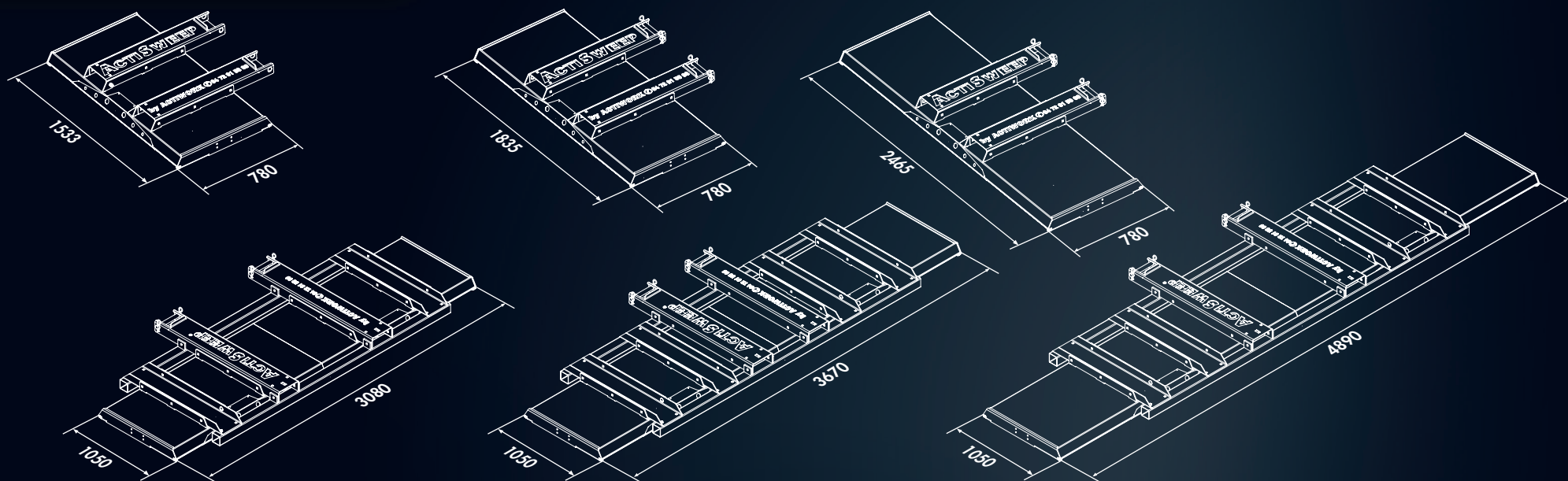

BRUSHES EASY TO REPLACE

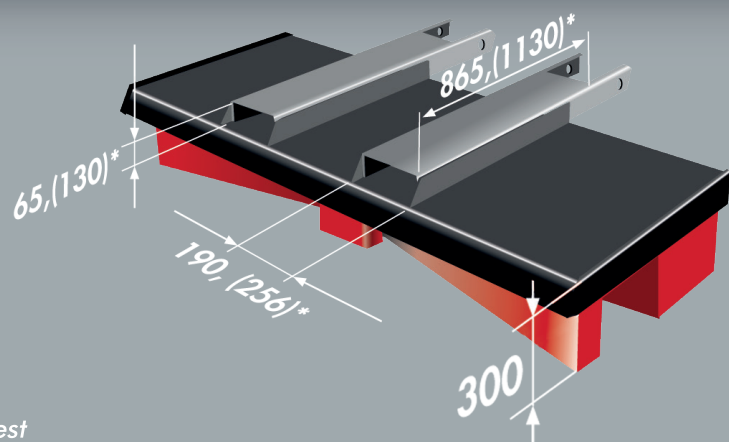

* Available on request

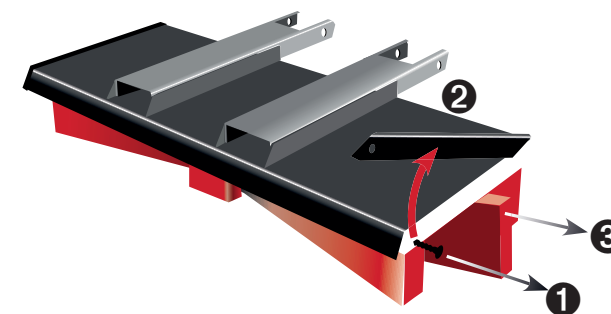

- 1- Unscrew a bolt on each connector
- 2- Lift up the connectors
- 3- Remove the brushes

STANDARD FORKS

- ↳ Adaptation for forks on forklift trucks
- ↳ Suitable for all types of forks with dimensions smaller than 256 x 130 mm
- ↳ 2 inserts with wedge pins for fast connection of the sweeper to the forks
- ↳ Heat-galvanized steel design

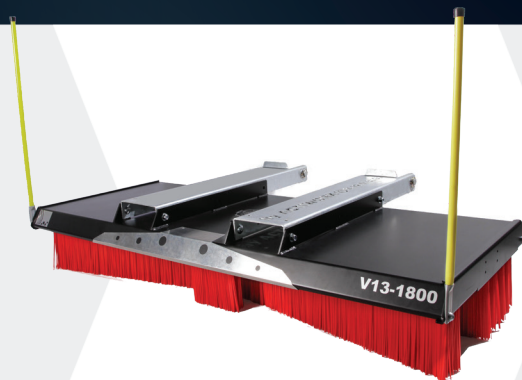

STANDARD BUCKETS

- ↳ Universal version for standard buckets and forks
- ↳ Suitable for all types of buckets and forks
- ↳ Consist of 2 steel parts connected to the standard forks adaptation
- ↳ Heat-galvanized steel design



BALE GRABBER

- ↳ Universal version for bale grabbers and forklift forks
- ↳ Suitable for all types of grabbers and forks
- ↳ Heat-galvanized steel design
- ↳ Dimensions:
L 1055 x I 700 x H 700 mm
- ↳ Inserts for grabber, maximum dimensions:
height 525 mm and thickness 90 mm

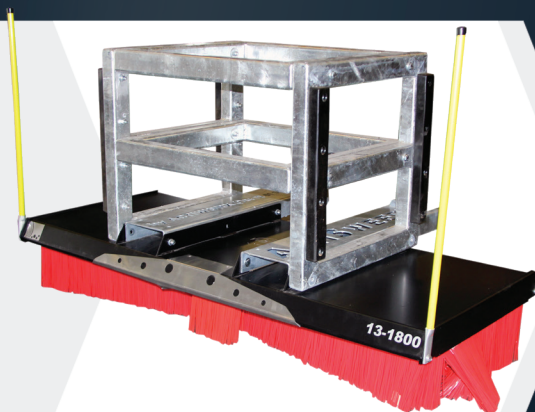

LOADER (ALLIGATOR CLIP BUCKET)

- ↳ Universal version for buckets and forks
- ↳ Suitable for all types of buckets and forks
- ↳ Robust design in thick galvanized steel
- ↳ Can be connected to the standard fork version



ADAPTATIONS

3 POINT ATTACHMENT

- ↳ Universal version for tractors
- ↳ Direct attachment to traditional 3 point systems
- ↳ Equipment assembled on the standard forks adaptation, so that the sweeper can also be used with forklifts
- ↳ Heat-galvanized steel design



LATERAL TRAVELLING KIT

- ↳ Forklift version
- ↳ Suitable for all types of forks
- ↳ Easier sweeping along walls or edges, especially when the vehicle is larger than the sweeper
- ↳ Heat-galvanized steel design



FRONT-END LOADER

- ↳ Fast attachment for all types of front-end loader (compatible with Maillieux, Fauchoux, Stoll, Quick...)
- ↳ Standard forks adaptation, so that the sweeper can be used with forklifts
- ↳ Heat-galvanized steel design



CUSTOM ADAPTATIONS

- ↳ ACTISWEEP can provide on request special custom adaptations to assemble the sweeper on your vehicle according to your needs

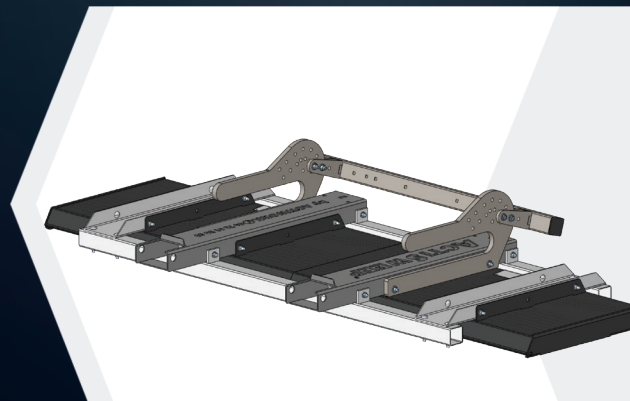

STORAGE LEGS

- Allows to lift-up the sweeper so that the brushes do not sag under the weight of the structure
- Allows to store the sweeper on a rack for more stability
- Heat-galvanized steel design



ANGULATION KIT

- Forklifts version, suitable for all types of forks
- Heat-galvanized steel design
- Allows to give an angulation to the sweeper in order to evacuate floor sweepings on the side (ex: snow removal or when sweeping roads or large areas)
- 10 fixed positions over 360°



STRENGTHENED FRAME

- Thick steel frame protecting the sweeper on its edges
- Provides frame protection in the event of an impact
- Robust heat-galvanized steel design

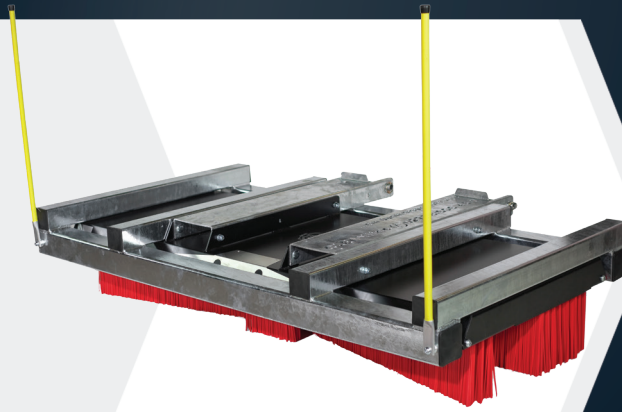

SIDE VISIBILITY STICK KIT

- 2 sticks (length: 1000 mm) to be fixed on each side of the sweeper
- Allows a better assessment of the size of the sweeper in order to avoid side impacts
- Fluorescent yellow sticks for a better visibility

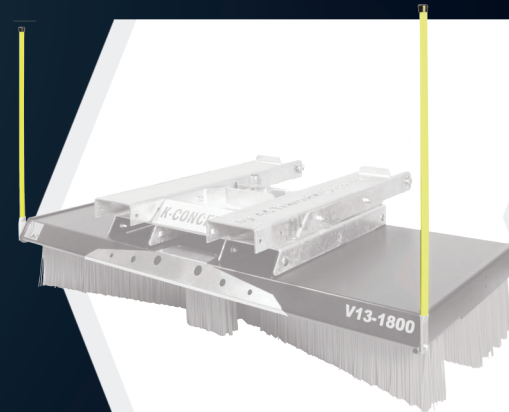

OPTIONS (V13-V9-V7)

ANTI-SCATTERING KIT

Allows :

- An easier sweeping along walls and sidewalks
- Materials to be collected in a second space when the "V" is full, thus doubling the retention capacity! No more windrows! This innovation is patented.



EXCESS MATERIALS ARE COLLECTED

MATERIALS ARE RECENTRED

EXCESS MATERIALS ARE COLLECTED

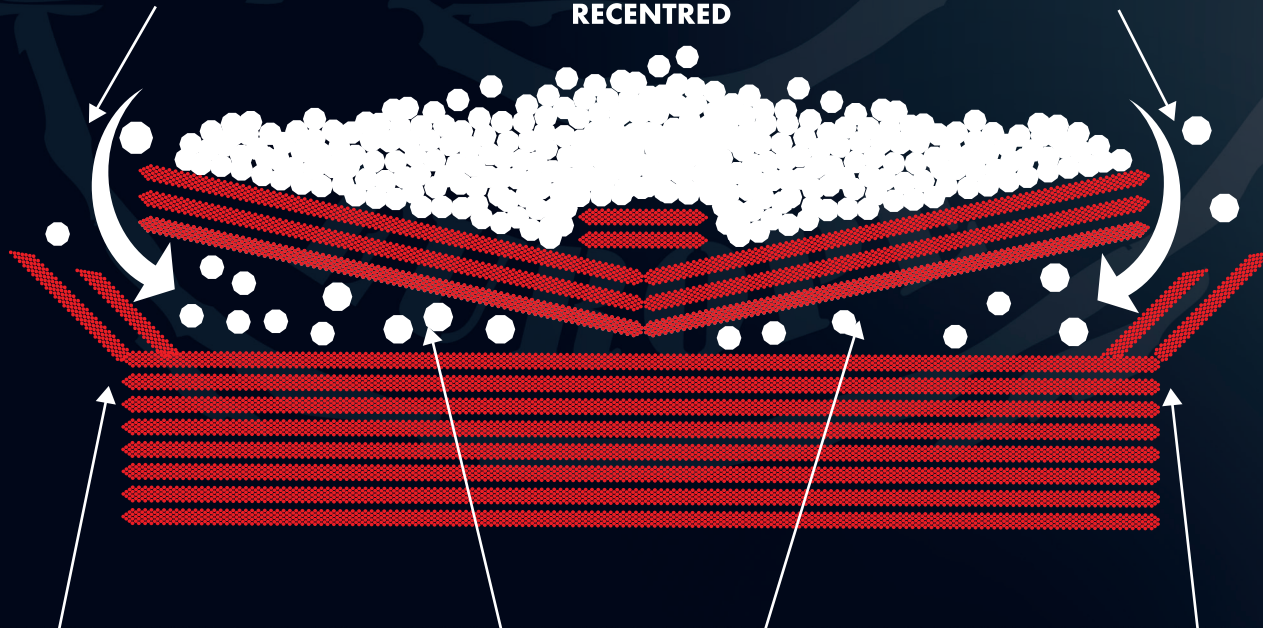

ANTI-SCATTERING SIDE BRUSHES

SECOND COLLECTION SPACE

ANTI-SCATTERING SIDE BRUSHES

■ Avoids a lot of manual work, especially along walls and sidewalks

■ Allows to collect materials in the space located behind the "V"

■ This option is to be assembled at the back of the metal connectors located on each side of the sweeper, thus protecting it from any distortion in the event of a side impact.

WALL

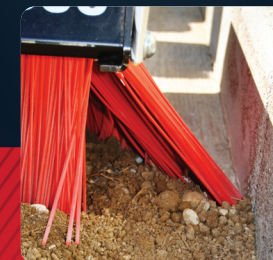

NEW (V13)

FINISHING BRUSH

This innovation makes it possible to obtain a higher quality sweep than standard bristle (red) thanks to its very thin bristle. For example : sawdust, sand, dust (such as cement, flour, potato...).

This option is only made of 5 rows of brushes. It is available on all widths but only useful on the V13.

**1 ROW OF BRUSH
WILL BE PLACED IN 3RD POSITION IN THE V-CONCEPT**



**4 ROWS OF BLACK BRUSHES
WILL COME BEHIND THE RED ROWS**



EFFECTIVE DOWN TO THE DETAILS



V7 MODEL

This sweeper is the first range product. Designed for simple applications on smooth surface (wheat, snow, aggregate...), the V7 sweeper has as indicated by its name 7 rows of brushes: 3 straight rows, 2 rows with a V-shape at the front to collect rubbish into the centre, and 2 mini-rows at the very front of the "V".
 3 widths available: 1500mm and 2400mm.
 This model is only available on pallet fork and the only option available is the anti-scattering kit.



Most frequent applications:



WHEAT



SNOW



LOGISTIC



GARDEN MACHINERY



SAWMILL



MATERIALS



**READY FOR USE:
5 TO 10 SECONDS ARE ENOUGH**



Insert the forklift blades



Block it, drive along and it's clean

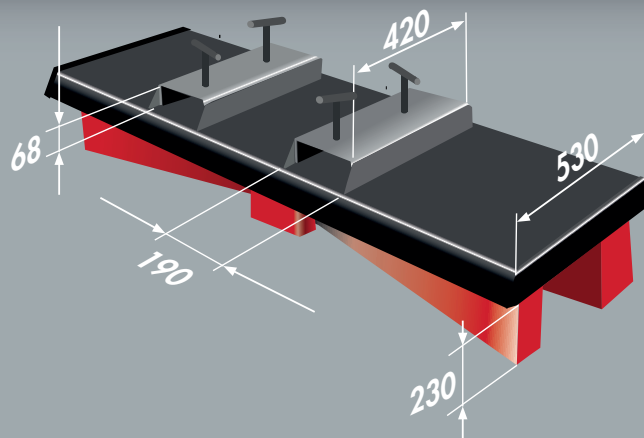

3 WIDTHS AVAILABLE: 1500, 1800, 2400MM

WHY **ACTISWEEP** ?

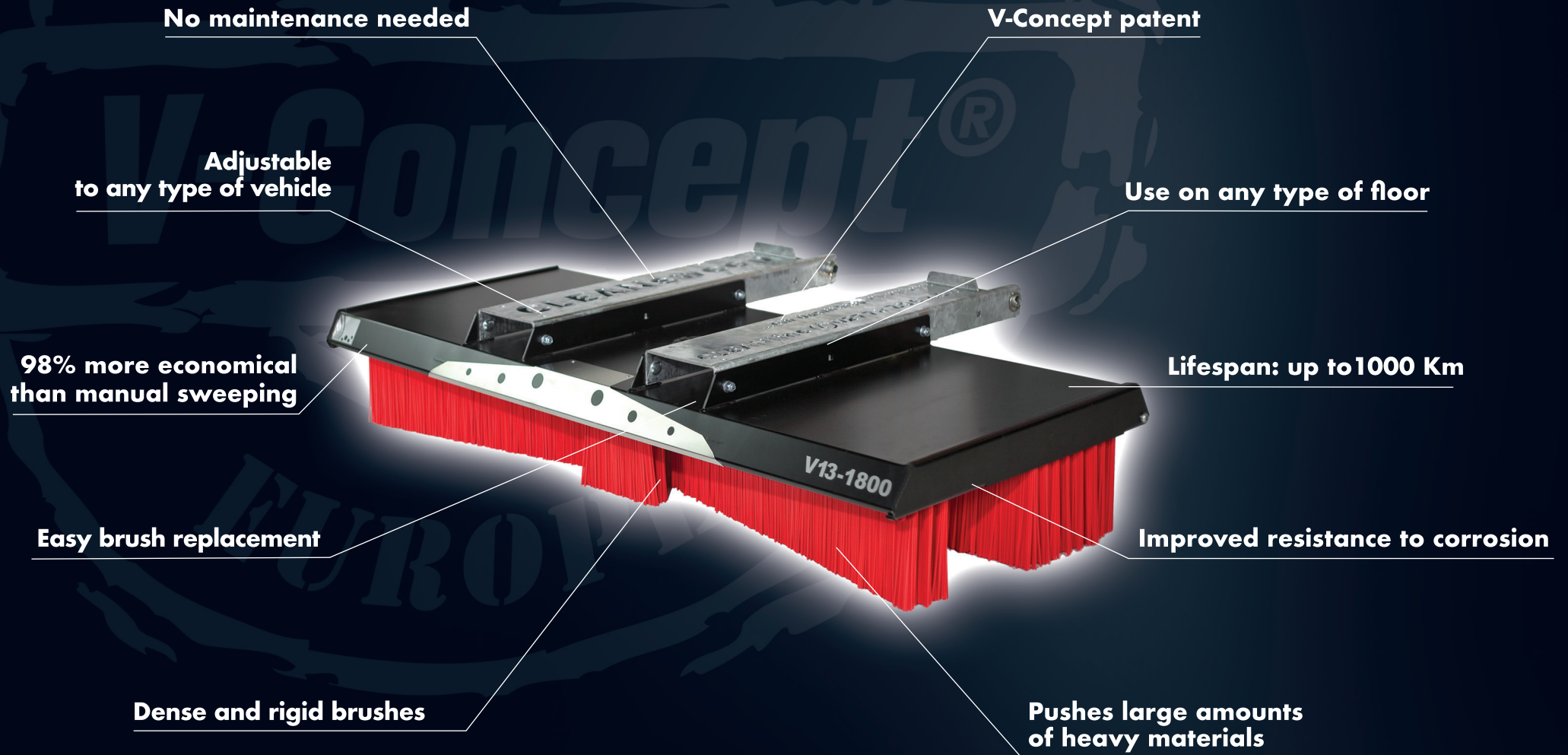

10 GOOD REASONS TO CHOOSE ACTISWEEP

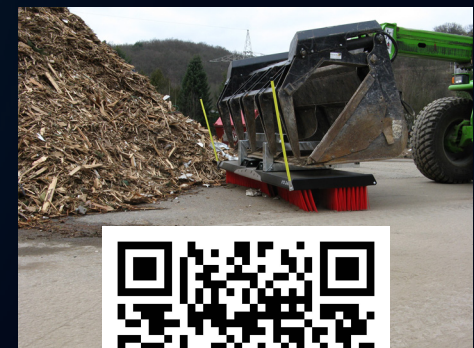
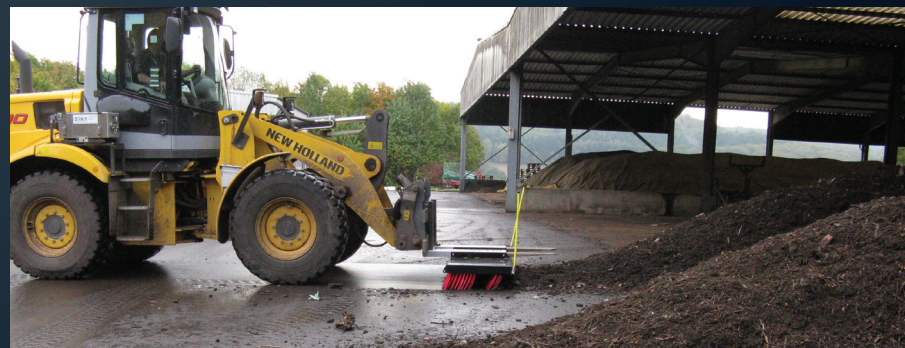
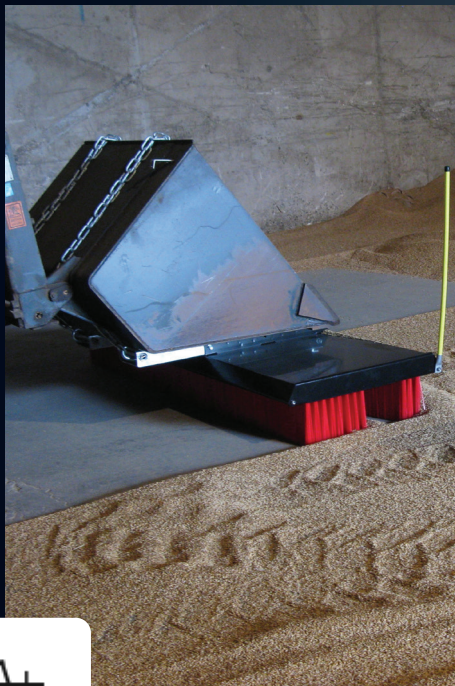

**VIEW MORE PHOTOS
OF APPLICATION ON-LINE**



CONSTRUCTION INDUSTRY & MATERIALS TRADING APPLICATIONS

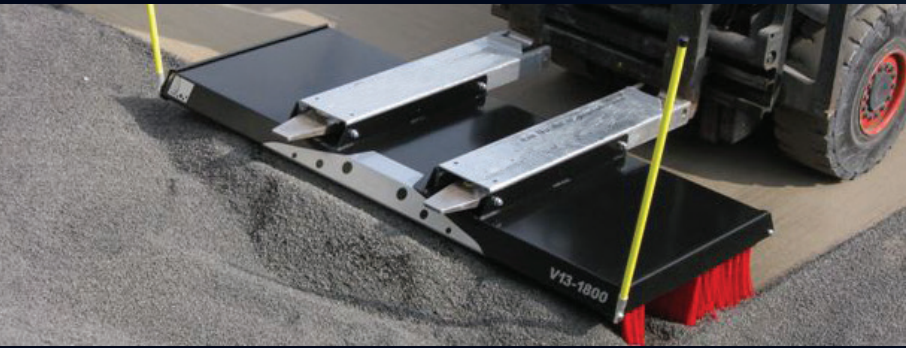



VIEW MORE PHOTOS OF APPLICATION ON-LINE



OTHER APPLICATIONS



COMPOSTING CENTER
(plant)



FLOOD
(mud on floor)

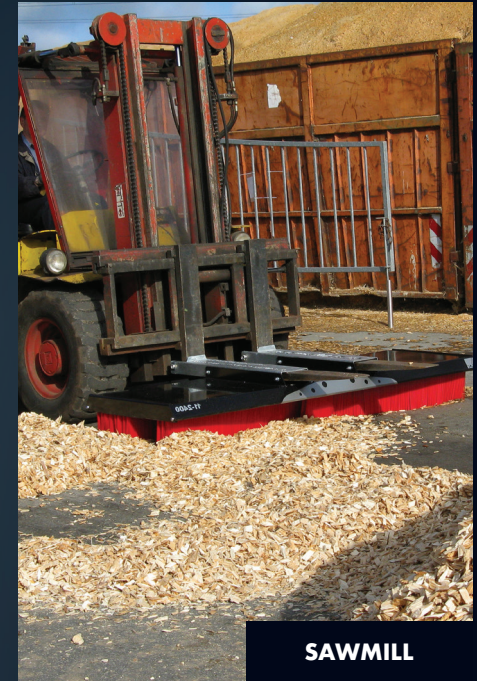

SAWMILL



SNOW



NURSERY



WATER
(cargo port)



GRAVEL
(cargo port)

A MANUFACTURER AT **YOUR SERVICE**



OUR PREMISES



OUR PRODUCING DEPARTMENT



LOGISTICS & TRANSPORTION



AGRICULTURE



RECYCLING



INDUSTRY



MATERIALS TRADING



DISTRIBUTION (HARDWARE SHOPS/STORES)



THEY TRUST US

IF YOU STILL HAVE A DOUBT, WE HAVE VIDEO ACCOUNTS AVAILABLE BY FLASHING THE QR CODE JUST BELOW...

ASK FOR A FREE TRIAL!



Your distributor



+33(0)4 72 01 50 60
(prix d'un appel local)



contact@actisweep.com



ACTIWORK
260, rue des Barronnières
01700 BEYNOST